

Ultrafast Fibre UFB Services Agreement
Bitstream Services:
Service Description for Multicast Service

1 Interpretation

- 1.1 The Multicast Service described in this Service Description will be available from the date it is launched by the LFC. The LFC will notify the Service Provider of the launch date for the Multicast Service.
- 1.2 References to clauses or sections are references to clauses or sections in this Service Description unless expressly provided otherwise. The definitions set out in the General Terms and the Operations Manual apply to this Service Description unless expressly provided otherwise.
- 1.3 References to the Operations Manual are references to the Operations Manual for the Bitstream Services.

2 The Multicast Service

- 2.1 The Multicast Service provides the ability to broadcast one or more media streams to multiple users simultaneously within a geographical region. Multicast is part of the UFB family of Bitstream Services:

Bitstream 2	Based on the TCF Mass Market service.
Bitstream 3	Based on the TCF Business service.
Bitstream 3a	Based on the TCF Business service with Low Priority options.
Bitstream 4	Based on the TCF Business Premium service.
UFB Handover Connection	Based on the TCF E-NNI specification.
Multicast	Based on the TCF Ethernet Multicast Access (EMA) service.
ATA Voice	An analogue telephone access service.

- 2.2 A diagram of the configuration for Multicast Service is set out in Appendix A. The Multicast Service supports the broadcast over an N:1 VLAN of a single media stream delivered at the Handover Point to all subscribed users within the coverage areas supported by the Handover Point.
- 2.3 The technical specification of the Multicast Service is set out in Appendix B.
- 2.4 The Multicast Service is an input service which the Service Provider can combine with its own network, servers and content delivery networks to provide an IPTV broadcast service to End Users. The Multicast Service can also be used for other broadcast media.
- 2.5 The Multicast Service has the following key characteristics:
- 2.5.1 A Layer-3 aware Layer 2 multicast solution based on Broadband Forum TR-101 and TR-156 technical standards, using IGMP snooping to support the Layer 2 multicast streams.
 - 2.5.2 Flexible bandwidth options to allow a range of different media streams or services.
 - 2.5.3 Provides the EMA service described in the Telecommunications Carrier's Forum's *Ethernet Access Service Description v24, 19 January 2011*.
- 2.6 The Multicast Service requires tight coupling with Service Provider media broadcast platforms and will require customisation and integration testing. The creation and modification of Multicast Domains will be managed through the Product Development Process and implemented using the Service Provider on-boarding process.
- 2.7 The Multicast Service will be delivered either:

- 2.7.1 As an incremental addition to a Service Template for existing Bitstream 2, Bitstream 3, Bitstream 3a or Bitstream 4 services; or
- 2.7.2 Packaged with Bitstream Services in new Service Templates constructed using the Product Development Process.
- 2.8 When provided with the Bitstream 2 Service, the Multicast Service can be provided either as:
 - 2.8.1 A VLAN over the UNI port carrying the Bitstream 2 Service with a data charge applying, as detailed in the Price List; or
 - 2.8.2 As a separate UNI port with a port charge applying, as detailed in the Price List.
- 2.9 When provided with the Bitstream 3, Bitstream 3a or Bitstream 4 Service, the Multicast Service can only be provided as a separate UNI port with a port charge applying as detailed in the Price List.

3 Multicast service and implementation activities

Installation Services

- 3.1 The Multicast Service is delivered to the UNI port on an ONT.
- 3.2 If the Service Provider requires additional services such as:
 - 3.2.1 Premises wiring; or
 - 3.2.2 Installation and testing of Service Provider equipment and services,
 then the LFC may be able to provide these on request, subject to terms to be agreed between the LFC and the Service Provider.

Core Multicast Services

- 3.3 The core bitstream services provided as part of the Multicast Service are as follows:
 - 3.3.1 The Multicast Services provides the ability to broadcast media streams by sending a single stream down each transmission path and replicating them for each divergent path at switching points. Media streams are only sent down paths that lead to End Users who have subscribed to that stream.
 - 3.3.2 The Multicast Service uses a dedicated multicast N:1 VLAN. The Multicast Service is delivered as:
 - (a) A single VLAN at the UNI/ETP at each End User site; and
 - (b) A single 802.1ad VLAN at the Handover Connection. The Handover Connection can also be configured for Cisco QnQ Ethertypes.
 - 3.3.3 Multicast traffic must be tagged as PCP 4. Frames with tags 0, 1, 2, 3, 5, 6 or 7 will be discarded.
 - 3.3.4 The Multicast Service consists of two parts:
 - (a) The *Multicast Domain* is a geographic area that supports the broadcast of media streams to all End Users in that area. Multicast Domains are created or modified using the Product Development Process.
 - (b) The *Multicast Connection* allows an End User to subscribe to and access a Multicast Domain.

Multicast Domains

- 3.4 A Multicast Domain consists of:
 - 3.4.1 The geographic area in which the Multicast Service instance is available. In particular:
 - (a) A Multicast Domain can be a single geographic area, or several non-contiguous areas; but

- (b) Each area must have one, and only one, UFB Handover Connection that serves that area.
- 3.4.2 Defined attributes and features set for that Multicast Domain.
- 3.5 Each Multicast Domain is associated with one Service Provider. However Multicast Domains from different Service Providers can overlap enabling each area to be served by multiple Service Providers. Each Service Provider's Multicast Service will be delivered over different N:1 VLANs and as a separate UNI and/or VLAN at the End User Premises.
- 3.6 Multicast services are available to all End Users within the geographic area(s) covered by that Multicast Domain.
- 3.7 As the Multicast Service requires tight coupling with Service Provider media broadcast platforms, requests for the creation and modification of a Multicast Domain will be implemented and delivered through the Product Development Process. This process includes pricing, development, testing and the option to combine different Bitstream Services into a single solution.
- 3.8 A Multicast Domain will be created using the following standard set of attributes and features:
 - 3.8.1 Geographic areas to be included in the Multicast Domain, including Handover Points;
 - 3.8.2 Total downstream speed is the sum of the bandwidth for each simultaneous media stream, e.g. five television channels at 10 Mbps = 50Mbps;
 - 3.8.3 Total upstream speed for control messages;
 - 3.8.4 IGMP snooping protocols;
 - 3.8.5 UNI attributes, e.g. dedicated or shared, tagged or untagged. The business rules are defined for the Multicast Domain but per-UNI attributes may be pre-specified or be capable of assignment on an individual Multicast Connection request;
 - 3.8.6 End User subscription bandwidth options limit how many simultaneous media streams an End User can receive; and
 - 3.8.7 Any other attribute required to deliver the Service Provider service and agreed by the LFC.

Multicast Connection

- 3.9 Multicast channels have a default bandwidth of multiples of 10 Mbps, to support a single HD Video channel. Different bandwidths may be requested using the Product Development Process.
- 3.10 An End User must have a Multicast Connection in order to access a particular Multicast Domain. One Multicast Connection is needed for each Multicast Domain to which the End User subscribes.
- 3.11 The Service Provider will subscribe each applicable End User to the Multicast Domain by lodging a Service Request for a Multicast Connection.
- 3.12 End Users can access all media streams within the Multicast Domain. Access to an individual media stream is done through IGMP control messages. Blocking of End User's access to individual streams, i.e. admission control, is the responsibility of the Service Provider.
- 3.13 An End User that is subscribed to a Service Provider's Multicast Domain will be limited to their subscribed bandwidth. If End Users attempt to access media streams greater than this bandwidth, then multicast frames will be dropped randomly. For example, a pay TV Service Provider has a Multicast Domain that supports 30 channels. An End User has a Multicast Connection that supports two channels. The End User can watch any two of the 30 channels simultaneously, but if they want to watch a third channel they must stop receiving one of their current channels first.
- 3.14 The End User must have a Multicast Connection capable of receiving the media streams. In particular:
 - 3.14.1 The multicast bandwidth available to an End User is dependent on the multicast bandwidth available on the shared PON.

- 3.14.2 As the aggregation and transport multicast network is not End User aware, the Service Provider is responsible for per End User admission control, i.e. ensuring an End User does not attempt to receive multicast traffic they have not subscribed for. For example, an End User that has subscribed to a single HD channel should be blocked by the Service Provider from requesting two simultaneous HD channels.
- 3.15 The Multicast Connection includes the options, exercised by Service Request, to set the UNI as an untagged interface. If this feature is requested then the network will remove all 802.1q tags from downstream direction and presented as 802.3 Ethernet frames to the UNI.
- 3.16 By default upstream IGMP will be forwarded through the multicast VLAN. The behaviour for tagged and untagged interfaces will be defined as part of the Multicast Domain.

UNI – NNI characteristics

- 3.17 All services on a UNI must belong to the same Service Provider and must connect to an E-NNI belonging to that Service Provider. However each Bitstream Service on that UNI can connect to a different E-NNI.

New Service Template Options

- 3.18 A Service Provider may request that the LFC create additional Service Templates using the Product Development Process set out in the Operations Manual.

Operations, Administration and Maintenance

- 3.19 The Multicast Service will support Ethernet Service Operations and Maintenance (**OAM**) for service integrity testing, fault diagnostics and performance measurement with the intention of compliance with ITU Y.1731 as appropriate. OAM capability will be phased in as the functionality is developed and deployed in scale.

Service Requirements

- 3.20 To use the Multicast Service the Service Provider must have the capability to access and interconnect with it, by one of the following:
- 3.20.1 Co-locating Service Provider equipment at the POI using the UFB Handover Connection Service and Central Office and POI Co-location Service;
 - 3.20.2 Connecting to third party co-location space at the POI using the UFB Handover Connection Service, and with the third party taking the Central Office and POI Co-location Service;
 - 3.20.3 Connecting to a backhaul service at the POI; or
 - 3.20.4 By using the Direct Fibre Access Service to connect to Service Provider equipment at a remote location within the Central Office area.

Additional Service Characteristics

- 3.21 The LFC will provide certain support and other assistance as part of the Multicast Service including:
- 3.21.1 An automated facility for Service Requests;
 - 3.21.2 An automated facility for fault notifications; and
 - 3.21.3 A tool to assist the Service Provider in determining the location and availability of the Multicast Service (pre-qualification),
- each as more particularly set out in the Operations Manual.
- 3.22 The Multicast Service specifically excludes:
- 3.22.1 The UFB Handover Connection Service;
 - 3.22.2 Provision or maintenance of any cabling or connection or active device:
 - (a) beyond the service demarcation points described in clauses 4.1 and clause 5.2;

- (b) between the jack terminating the LFC provided Fibre Lead-in and the ONT where that cabling or connection is not provided by the LFC and the LFC has not agreed to take responsibility for that cabling or connection;
- 3.22.3 Configuration, monitoring, operation, on-going support or maintenance of Service Providers' or End User applications, equipment or networks; and
- 3.22.4 Supply of AC mains & UPS power, accommodation space, heating, ventilating, and air conditioning at the POI or End User Premises.

4 Service Demarcation Point at End User Premises

- 4.1 The service demarcation point at the End User's Premises is the 100/1000 Base-T UNI on the ONT.
- 4.2 The Multicast Service excludes the End User Premises wiring. If a fault reported by the Service Provider is found to be caused by the End User Premises equipment (**CPE**) or the wiring at the End User's Premises beyond the service demarcation point, then the Service Provider may be charged the no fault found fee in the Price List. Note the wiring should comply with the industry standard Premises wiring requirements which are available at www.tcf.org.nz.

5 Service Demarcation Point at POI

- 5.1 The Multicast service is delivered as a single VLAN (the logical service demarcation point) on the Handover Connection located at the POI.
- 5.2 The physical service demarcation point is the MOFDF in the POI, which is part of the UFB Handover Connection.
- 5.3 The UFB Handover Connection Service is a separate service and is a prerequisite to the supply of the Multicast Service, i.e. Service Provider's must first purchase and then continue to maintain a UFB Handover Connection Service at all times while taking the Multicast Service.

6 LFC and Service Provider Responsibilities

- 6.1 Other LFC and Service Provider responsibilities are detailed in the General Terms and the Operations Manual.

7 Service Level targets

- 7.1 Service Levels for the Multicast Service are set out in the Service Level Terms for the Bitstream Services.

Appendix A – Diagram

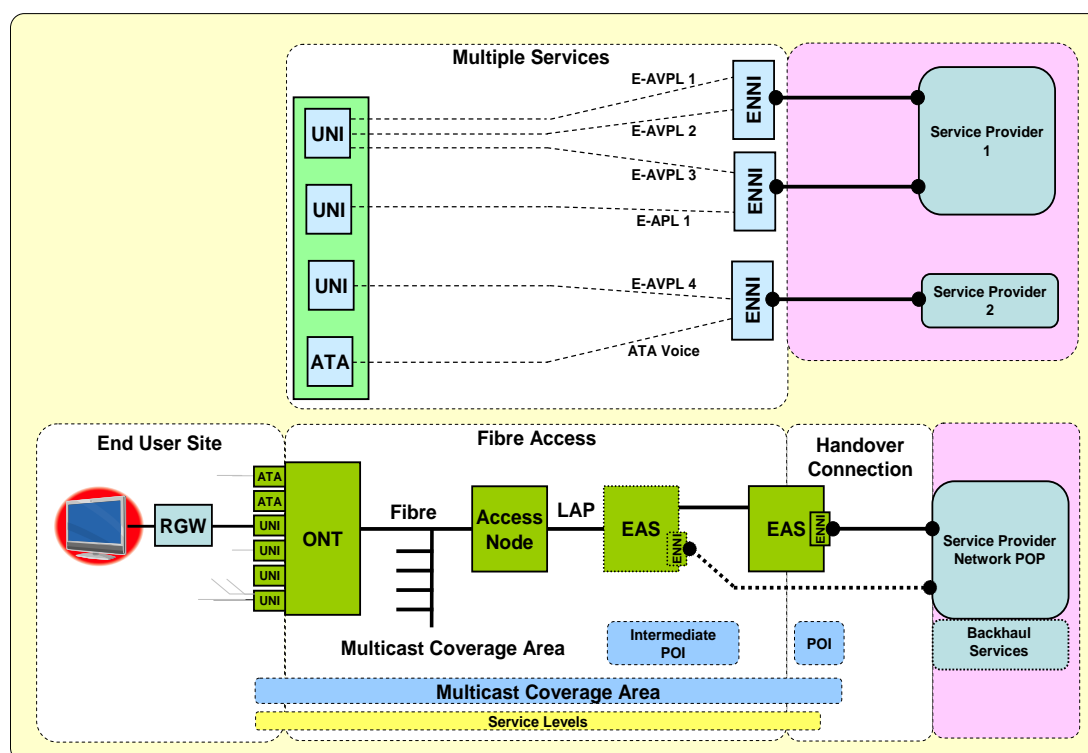

This is a generic diagram showing the standard configuration and service demarcation points. It is not intended to represent every situation or detailed physical architecture. The following points should be noted:

- Multicast Domains consist of a geographic area that consists of all Fibre Access Nodes served by a POI;
- The Multicast Service and pricing applies from the UNI to the E-NNI at the POI, i.e. there is no incremental charge from the Intermediate POI to the POI.
- Some Bitstream Services will have a single tier of aggregation, i.e. there is no Intermediate POI.
- Where there are multiple tiers of aggregation, the Service Provider can pick the service up at an Intermediate POI. This intermediate POI will service a limited Coverage Area.
- Service Levels (availability, network performance) only apply to UNI to the E-NNI at the POI.
- Access node and aggregation interconnection may use redundant links to meet Service Level requirements.

The Bitstream Services support simultaneous delivery of multiple Service Templates from the same or multiple service providers as follows:

- Multiple E-AVPLs can be delivered to the same UNI.
- An E-APL service requires a dedicated UNI.
- An ATA Voice service can be considered an E-AVPL with an ATA Port at the End User interface. The class and bandwidth characteristics of this E-AVPL are optimised for voice.
- All services delivered to a UNI must belong to the same Service Provider but can be mapped to the same or different E-NNIs.
- The Multicast Service will typically be included in a Bitstream 2, 3 or 3a Service Template, but can be added as an incremental service to an End User who is consuming a different Bitstream Service from the same or different Service Providers.

Appendix B – Technical Specification

Technical Specification	
IGMP and MLD support	IGMP snooping using IGMP v2 (RFC2236) and v3 (RFC3376) for IPv4. MLD snooping supporting MLD v2 for IPV6 (RFC3810).
Ethernet	Ethernet II or 802.3 untagged interface; or 802.1q tagged interface with: <ul style="list-style-type: none"> • VLAN id = Agreed as part of setup; or • 802.1p = 4.
UNI	ONT supports: <ul style="list-style-type: none"> • 4 x UNI; and • 2 x ATA Voice ports. • Optional additional ports: <ul style="list-style-type: none"> ○ RF Overlay port; and ○ WiFi. Per UNI: <ul style="list-style-type: none"> • 100/1000 Base-T; and • IEEE 802.3 – 2005.
UFB Handover Connection (E-NNI)	Ethernet: <ul style="list-style-type: none"> • 802.1ad VLAN (svid, cvid); or • Double tagged QnQ.
VLAN	N:1 VLAN. MTU 2000 Bytes. Unicast Frame Delivery = passed within service CIR/EIR*. Multicast Frame Delivery = passed within service CIR. Broadcast Frame Delivery = passed within service CIR/EIR*. Downstream traffic limited Multicast only. Upstream traffic UNI to E-NNI, for Multicast control traffic only. * As agreed with the LFC as necessary to support multicast traffic during product development. Layer 2 Control Protocols Processing = initially none (but may be amended by the LFC from time to time).